



BRIEF INFORMATION

K-LED Nano

- Very compact design with high light intensity
- Vibration and impact-resistant
- High degree of tightness thanks to complete sealing

PRODUCT FEATURES

Small, smaller, Nano!

Despite its compact dimensions, the K-LED Nano gives out an above-average light intensity. HELLA's smallest homologated beacon to date generates a long-range, amber warning signal by means of flashing light. The standard version for fixed mounting is characterised by a slightly curved base which, with a bolt circle diameter of 130 mm, stays true to the usual HELLA mounting points. Further mounting options deviating from this standard are possible (e.g. a bolt circle diameter of 43 mm or 85 mm).

In addition, a variant with flexible pipe socket mounting is also available. The shock-absorbing and vibration-damping base briefly tilts the beacon by up to 45° and cushions even strong impacts. Thanks to this option and the complete sealing of the beacon, the K-LED Nano can therefore also be used both in vibration-intensive environments and also in dusty ones. As a Fit&Forget solution, following installation the beacon turns into a reliable and long-lasting vehicle component.

TECHNICAL DETAILS

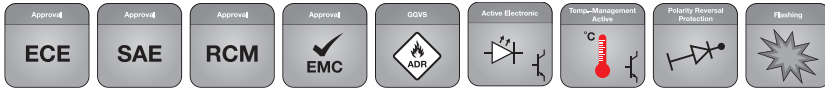

Technical data	
Operating voltage	Multi-voltage
Rated voltage	12 V / 24 V
Current consumption*	Approx. 1,6 A (12 V) Approx. 0,8 A (24 V)
Power consumption	Ø 5 W Max. 19 W
Light function	Flashing
Light source	LED
Temperature range	-40 °C to +60 °C
Protection class	IP 6K7, IP 6K9
Type approval	ECE R65 TA1 005218, SAE J845 Class 1
EMC protection	ECE R10, CISPR 25 Class 5, RCM
Connection	150 mm cable with 6.3 x 0.8 – 1.5 flat connector

* At max. power consumption

Dimensional sketch

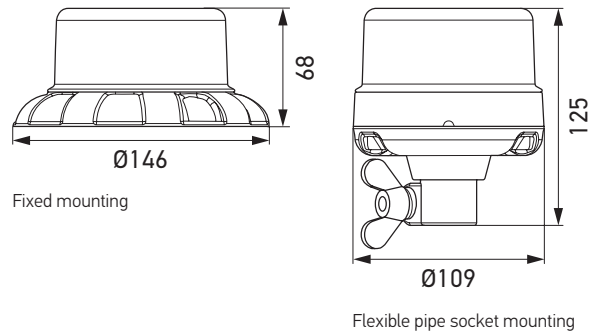



Small, smaller, Nano!









Compact dimensions and high light intensity. The K-LED Nano offers the right solution for fixed mounting and for pipe socket mounting.



PROGRAMME OVERVIEW

Product image	Type of mounting	Light function	Light colour	Part number
	Fixed mounting	Flashing	Amber	2XD 066 146-001
	Flexible pipe socket mounting	Flashing	Amber	2XD 066 146-011

ACCESSORIES

Product image	Description	Part number
	Latching changeover switch, 2-pin, 1 position	12 V: 6FH 353 100-031 24 V: 6FH 353 100-191
	Socket pipe for welding on, straight, 100 mm long, with rubber stopper and socket, in accordance with DIN 14620	1-pin: 8HG 002 365-001 2-pin: 8HG 006 294-101
	Socket pipe with screw-on base plate, total height 126 mm, with rubber stopper and socket, in accordance with DIN 14620	1-pin: 8HG 006 294-011 2-pin: on request
	Angled socket pipe with base plate for lateral screw attachment, clearance 90 mm, height 100 mm including rubber stopper, socket, 2x hexagon screws M8 x 35, 2x hexagon nuts M8, 2x spring washers, compliant with DIN 14620	1-pin: 8HG 006 294-021 2-pin: on request
	Angled socket pipe with base plate for lateral screw attachment, clearance 50 mm, height 100 mm including rubber stopper, socket, 2x hexagon screws M8 x 35, 2x hexagon nuts M8, 2x spring washers, compliant with DIN 14620	1-pin: 8HG 006 294-111 2-pin: on request
	Socket pipe for inclined screw-on surfaces, beacon adjustable parallel to the roadway, height approx. 105 mm, with rubber stopper, socket, 2x hexagon screws M8 x 35, 2x hexagon nuts M8, 2x spring washers, compliant with DIN 14620	1-pin: 8HG 006 294-031 2-pin: 8HG 006 294-141
	Socket pipe with screw mounting, height approx. 100 mm, with rubber stopper and socket, compliant with DIN 14620	1-pin: 8HG 006 294-051 2-pin: 8HG 006 294-091
	Socket pipe with 2 screw holes for surface mounting to the cab rear, with telescopic bracket, total height approx. 1,000 mm, can be shifted up to 700 mm, with rubber stopper and socket, compliant with DIN 14620	1-pin: 8HG 006 294-041 2-pin: on request