



RotaLED Compact



REAL RELIABILITY AT AN AFFORDABLE PRICE!

RotaLED Compact really scores points with its durability and its flashing light function never fails to give a powerful warning. And because the fixing points remain exactly the same, existing halogen beacons can be replaced so simply by LED's. It really pays off!

THREE VERSIONS – MAXIMUM FLEXIBILITY

Whether using magnetic attachment for fixed installation or flexible pipe sockets: RotaLED Compact is suitable for many application areas thanks to its many assembly options. No matter, which version you decide on, RotaLED Compact convinces thanks to its noticeable LED flash function and the absence of movable parts, providing maximum reliability and a strong warning effect.



Fixed attachment
2XD 013 979-001



Flexible pipe socket
2XD 013 979-011



Magnetic attachment
2XD 013 979-021

HIGHLIGHTS

Flashing light function

Double-flash signal for maximum attention – 360° warning effect.

Modern LED technology

No servicing and cost efficient.

Long service life

Hard wearing and maximum reliability for reduced down times.

Robust and vibration-resistant

Impact-resistant dome and absence of movable parts.

Compatibility

Rotafix, Rotaflex and Rota Compact are exchangeable 1:1 for RotaLED Compact.

Flexibility

Flexible pipe socket version softens strong impacts and minimises damage risks.

Optimum price-performance ratio

Maximum technology at minimum price.



Display in original dimensions

ONE FOR ALL

RotaLED Compact is the LED successor of the existing halogen beacon series Rotafix, Rotaflex and Rota Compact – and combines the known advantages of the beacon series with new, innovative product characteristics, such as LED flash function without movable parts.

Throughout, the existing beacons can be exchanged 1:1 against the successor model. Users of the previous halogen version can therefore quickly and easily benefit from the advantages of RotaLED Compact.



1:1 exchange: Rotaflex against RotaLED Compact



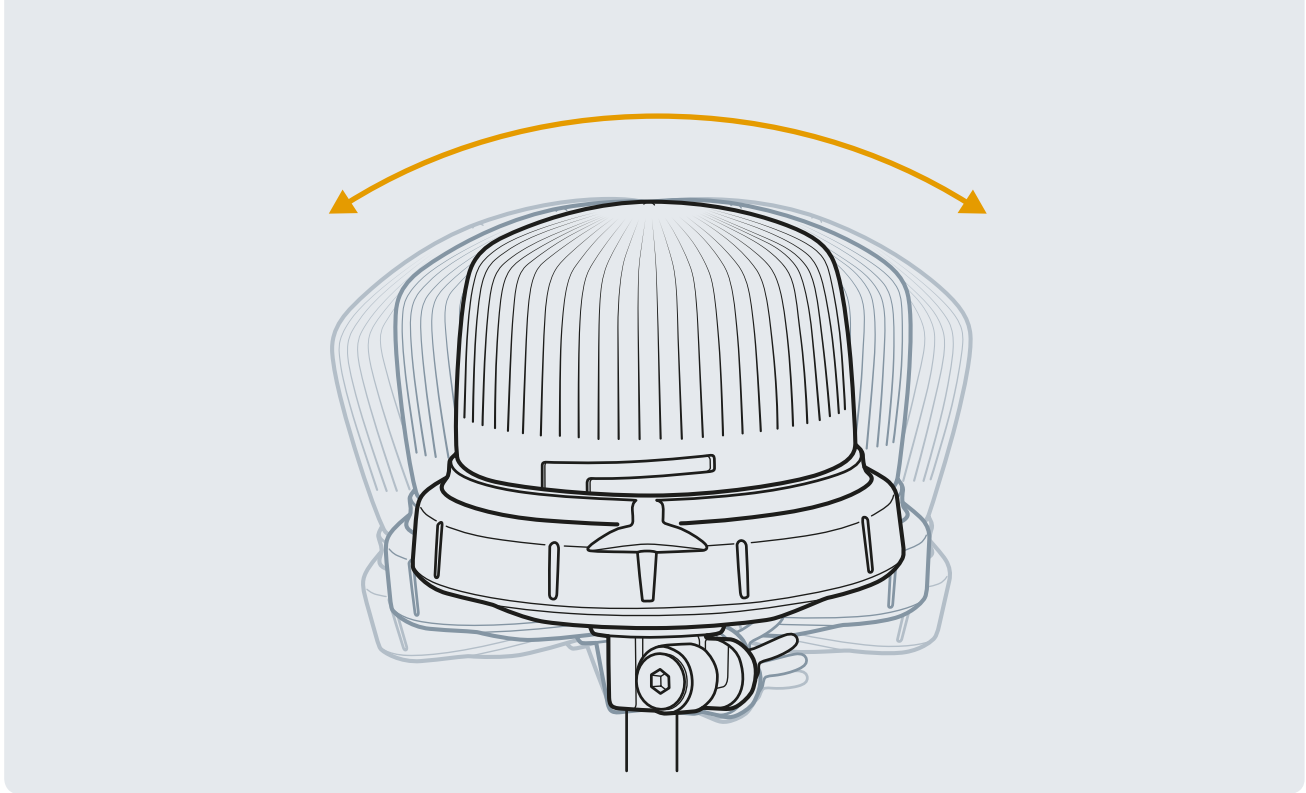

EXTREMELY FLEXIBLE

The flexible foot of the RotaLED Compact FL softens hits and impacts thanks to its special design. The lamp will always return to its original position; this significantly reduces the risk of damage. RotaLED Compact is therefore fully protected, e.g. against suspended branches of any size.



Beacon default position



If the beacon inclines by up to 30°, it returns to default position.



At extreme inclinations of more than 30°, a special protective mechanism at the base is activated: it prevents the beacon from remaining in overly inclined positions.



How does the protective mechanism work?
The interlocking of the rubber base and housing is released. This ensures that the beacon will not be damaged. Should an extreme inclination develop, the beacon can be reset to default position by loosening the three screws at the pipe socket.

ROTALED COMPACT – REAL POWERFUL AS...



...HARVESTER – ALWAYS THERE WHEN NEEDED

Long operating periods, strong loads: field and harvest works are an ideal application for the RotaLED Compact – convinces through high resistance and cost-effectiveness.



... ROAD MAINTENANCE – STRONG WARNING EFFECT ON ROAD SHOULDER

A good warning effect and great reliability during daily use on the road: RotaLED Compact provides both – and is therefore ideally suited for municipal vehicles.



... WORK HORSE – ALWAYS STRONG AT YOUR SIDE

Dust, dirt, hits and impacts on construction sites? No problem for the impact-resistant and flexible RotaLED Compact, suited optimally for the use on construction machines.



Detailed information can be found at:
www.hella.de/municipal

HELLA Fahrzeugteile Austria GmbH

Target Group Land-, Baumaschinen
und Spezialfahrzeuge
Handelskai 94-96
A-1200 Wien
Tel. +43 (0) 1 606 89 20
Fax +43 (0) 1 606 89 20-1291
E-Mail: info-ag-ce@hella.at
www.hella.com/agro

HELLA Asia Singapore Pte Ltd

Regional Headquarters Asia Pacific
Independent Aftermarket
2 International Business Park
#02-12 The Strategy
Singapore 609930
Tel: +65 6854 7300
Fax: +65 6854 7302
E-mail: singapore@hella.com
Internet: www.hellaasia.com

HELLA Automotive South Africa (Pty) Ltd

P O Box 603
Uitenhage
SOUTH AFRICA
6230
Tel.: +27 (0) 41-996-5700
Fax.: +27 (0) 41-996-5720
<http://www.hella.co.za>

© HELLA KGaA Hueck & Co., Lippstadt
922 999 139-715 J01322/KB/04.17/0.43
Printed in Germany
Subject to technical and price modifications.