



## BRIEF INFORMATION

### Power Beam 1000 compact

- Perfect LED work light as a halogen substitute
- Shock-resistant, plastic housing
- Successor to the successful Power Beam 1000 LED

## PRODUCT FEATURES

The Power Beam 1000 compact is an ideal LED work light facilitating the changeover from halogen to LED technology. The work light is designed so that it can be used anywhere thanks to its compact dimensions. The innovative plastic housing also features cooling fins which ensure the required heat dissipation from the high-power LEDs. Along with weight reduction, the material offers the further advantage of being totally corrosion-resistant.

The light output from the six high-power LEDs is an impressive 1,000 lumens. The light is distributed by a specially developed multi-faceted reflector, thus ensuring homogenous illumination. Models with varying cover lenses lend themselves either for close-range or long-range illumination, as required. Energy consumption is just 12 watts of power. Because of such low energy consumption, the Power Beam 1000 is ideal for use in vehicles powered by batteries and in those where there are already significant demands on the alternator. The multivolt electronics of this headlamp are designed for vehicles with vehicle electric system voltage of 12 and 24 volt.

With a colour temperature of 6,500 kelvin, the light from the LED work light is very similar to daylight. This helps to distinguish colours more easily in the dark, and makes sensory perception through the eyes much easier. In turn, this prevents the eyes from tiring quickly when working at night.

The integrated electronics protect the device in the event of polarity inversion and guarantee constant brightness, even when operating voltage fluctuates between 10,5 and 32 volts. Temperature sensors additionally protect the work light from overheating. Only in this way can the long service life of the LEDs and a safe working environment at night be guaranteed.

# TECHNICAL DETAILS

## Technical Data

Operating Voltage / Rated voltage	10,5 – 32 V
Power Consumption	12 W
Light Output	1,000 lumens
Light Source Type	6 high-power LEDs
Colour Temperature	6,500 kelvin
Housing	Impact-resistant plastic
Mounting	Upright and pendant
Connection	DEUTSCH connector
Protection	Overheating and reversal polarity
Protection Class	IP 6K9K, IP 6K8
Type Approval	Ⓜ, ECE-R10, RCM, ADR / GGVSEB, ECE-R23 (Abart -521)
Weight	410 g
Manufactured in	Austria

## Dimensional Sketch

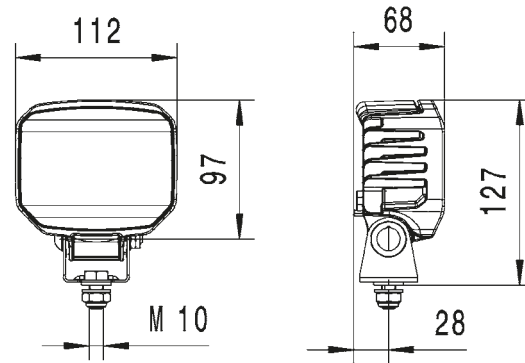

# RANGE OVERVIEW

1GA 996 188-...	-501	-511	2ZR 996 188-521
Close-range illumination	X	-	X
Long-range illumination	-	X	-
Swivelling base/bracket width	42 mm	42 mm	42 mm
Special Feature	-	-	ECE R23 reversing light approval

# LIGHT DISTRIBUTION

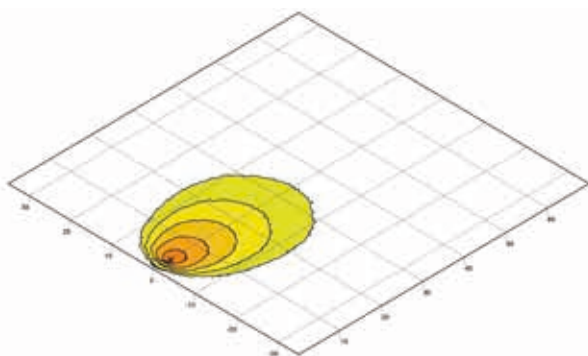

Close-range illumination

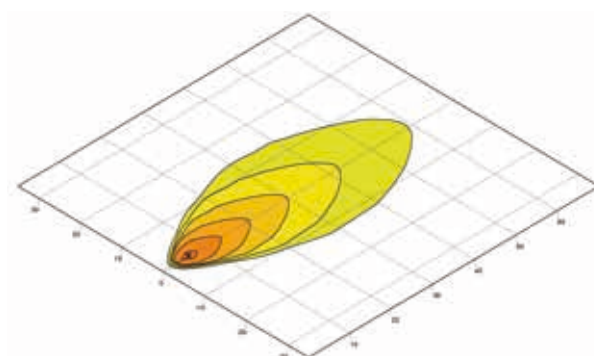

Long-range illumination

