



HELLA Technology
In Agriculture



HIGHLIGHTS



THE HELLA LED LIGHT BAR IS MOUNTED IN A FLASH

(Page 4)



THE LED WORK LIGHT – HOW IT ALL BEGAN

(Page 2)



WORK LIGHTS APP – FINDING WORK LIGHTS IS CHILD'S PLAY

(Page 5)

WORKING IN THE FIELDS OR AT THE SILO, THE GOLDEN RULE IS GOOD VISIBILITY

The days are getting longer again. For farmers and contractors that normally means that their working days frequently stretch over more than eight hours. The first grass cut of spring and the GPS season are around the corner and then autumn will be waiting with the silo corn harvest. The main agricultural season sees farmers commuting several times a day between their fields and the silo in a perfectly organised logistics system. The crop is unloaded at the silo, distributed and then immediately compacted. If all this work is to be performed efficiently with downtimes being avoided, then the choreography of the huge machines involved has to be perfectly timed and chimed. As all these tasks begin very early in the morning and last long into the night, it is essential to

have the right kind of light at dawn and at dusk. And in the end, good light is undeniably a decisive factor in the safety equation. These enormous, heavy-duty agricultural machines are up and down farm tracks just as much as they travel along regular roads. When discharging their load on the field and in the silo, such equipment can manoeuvre its way right down to the last centimetre. During such operations it is of paramount importance for the driver that the entire working area is brightly and evenly illuminated. The stage lighting for such a ballet performance with its technical pirouettes has to be perfect. So does the safety factor for everyone concerned. Enter the HELLA product portfolio centre stage with its show-stopping repertoire!

The New Ultra Beam LED Generation II

FROM THE FIRST IDEA TO THE SERIES PRODUCTION

The Ultra Beam LED Generation II is a high-powered light which eclipses many other kinds of work lights and which even succeeds in easily outshining xenon work lights. We have followed this development from the very first ideas and tests right up to the start of series production.



The Ultra Beam LED Generation II: 4,000 Lumens of Light Output.

With a huge helping of innovation and development expertise provided by a research team constantly intent on inspiring your customers day in day out, HELLA succeeds again and again in coming up with ultra innovational solutions. The HELLA work light known as the Ultra Beam LED Generation II attests to this. Thanks to its accurately measured 4,000 lumens of light output, this latest development in the most sold series of work lights worldwide offers a magnificent light output of a truly superlative kind. A huge variety of illumination possibilities and mounting variations offers ideal conditions for so many fields of application.

Stefan Maierhofer, global product manager for work lights:
"The Ultra Beam LED Generation II is heralding in the



Stefan Maierhofer is Global Product Manager for HELLA work lights.

continuation of a great chapter in our story. The Ultra Beam is our best selling work light of all time. It is quite a while now since we successfully launched an LED version of the Ultra Beam on to the market. We have now extended this by introducing the second generation, which succeeds in even

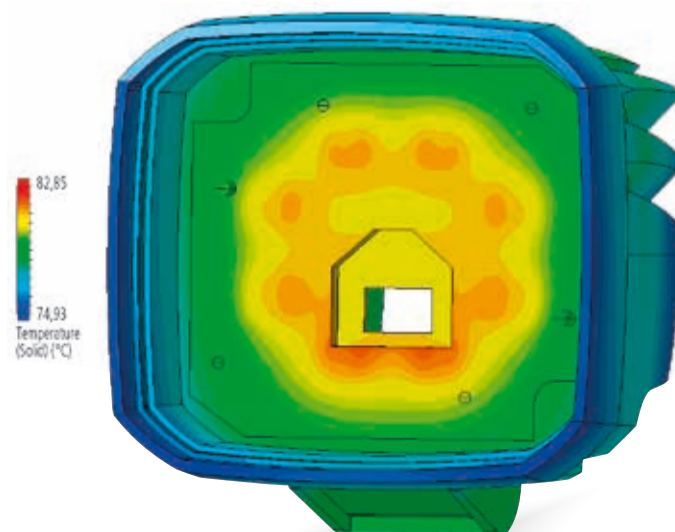

Thermal simulations indicate the temperature zones and heat distribution on the housing.

surpassing xenon work lights quite considerably. The bottom line here is that not only do we offer our customers top-flight products of supreme quality but also that we stay true to our corporate motto: Technology with Vision."

A quick glance at the Austrian state of Burgenland

A trip to the wonderfully picturesque state of Burgenland in the south-eastern corner of Austria will enable us to witness the coming to life of the Ultra Beam from the very beginning. There we find the site of the HELLA plant where ca. 90 % of the work lights required worldwide are produced. And it's from this location that the global HELLA network supplies so many diverse customer groups across all continents.

The idea and the product

A new product idea is triggered either by a direct customer inquiry via the sales department or it comes out of the product management "atelier" itself. During initial talks with technology experts to explore collaboration possibilities, requirements are put forward and discussed and the first solutions are suggested. Kick-off meetings are then held in order to discuss the previously generated ideas with all the departments involved. This is where the mechanical and technical requirements, the design of the work light and also the performance of the new light are all discussed. An essential factor in the equation is the lighting technology. It is all about the demands placed on the light output, it is about the various forms of illumination and also about the type of optical system. Taking these defined requirements as the bedrock for his creation, the designer then prepares the first mechanical concept.

- Creating of a first blueprint (design, structure, ...)
- Defining of the materials used
- Calculating of the rigidity in order to withstand all expected mechanical stress and strain.

As soon as the design of the work light has been defined, the Electronics department can begin drawing up its electronic concept. In close collaboration with their colleagues, the Lighting Technology department starts defining the LED type to be used, the number of LEDs to be included and also their positioning.

Simulation and prototype construction

Prior to the first prototypes being set up, the designer's mechanical concept is tested on the computer.

- Mechanical simulations (impact, influence of force)
- Thermal simulations (heat build-up, temperature discharge, ...)
- Simulation of illumination

This trial run is intended to show up any weaknesses in the embryonic stages so that fewer costs are incurred later. The results of the simulations enable the designer to finalise his mechanical concept. Once the computer simulations are positive, product development can be continued, tools made and suppliers commissioned.

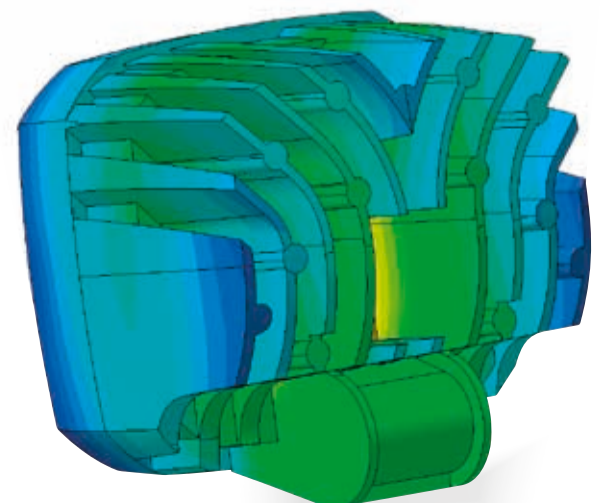

The aluminum heat sink enables quick dissipation of heat – incidentally an important quality criterion as regards work lights.



The main components of the Ultra Beam LED II.

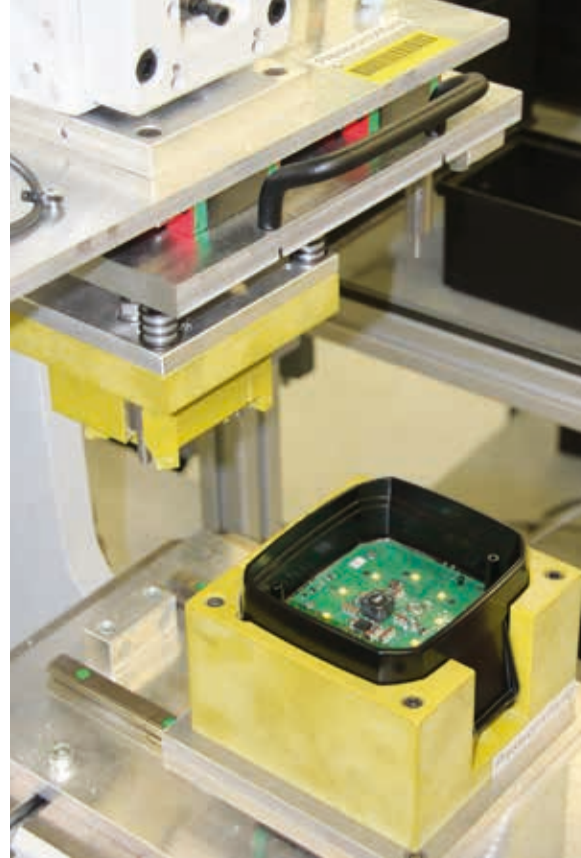

This is where the circuit board is bonded to the housing using heat conducting film.

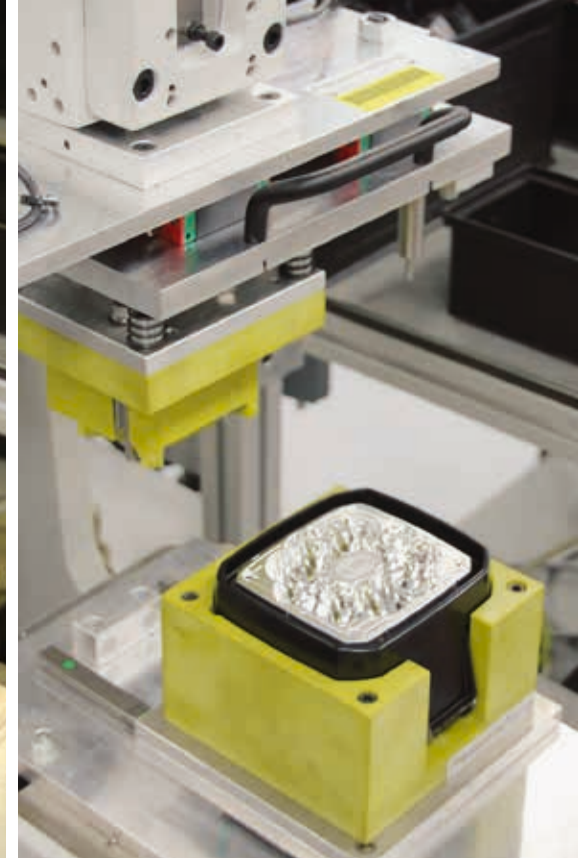

The reflector is centered in the housing by means of special dome-head pins.

Structure of a work light – the concept

A work light is basically made up of five main components:

→ Housing

The back of the robust aluminum housing is equipped with cooling fins which serve to cool the work light. So as to make the housing exceptionally robust, the aluminum is covered with a top-quality powder coating. This is vital as not only does the housing have to dissipate any heat generated but it also serves to protect the interior of the work light from any mechanical or chemical influences.

→ The Electronic Circuit Board

A circuit board of first-class quality is home to the electronic components and the LEDs. At full load, temperatures of up to 120°C can be reached here. Unlike a halogen light where heat is given off towards the front, here it is dissipated backwards. In order to improve heat flow, the circuit board is bonded into the aluminum housing by means of a special heat conducting film. This guarantees a controlled and even removal of the heat being generated.

→ Reflector + Cover Lens

This is where the wheat is separated from the chaff. Because a work light is only as good as the illumination it produces – and the reflector is responsible for that. The light beams generated by the LEDs are captured by the specially calculated reflective surfaces and then targeted into the work area. Only work lights with a reflector system are able to generate an even and homogeneous illumination of the work area. A textured cover lens is also implemented so that the light is spread widely. Here the light beams are once again deflected with the result that a wide and even light pattern is created. (Close-range illumination)

→ Brackets/Mounting Components

Vibration, impact and all manner of other mechanical factors make up the typical working day of a work light. So as to ensure that the work light, after having been mounted, permanently remains in the same position, special vibration-resistant rubber dampers are used to secure it even further. They make any tilting of the work light impossible. Even when powerful vibration occurs, the driver continues to enjoy excellent illumination of his working area.

Production

The assembly of LEDs is governed by particularly strict working conditions. Access is only allowed to authorised personnel. Members of staff are obliged to wear special antistatic clothing and shoes in order to prevent the occurrence of any electronic short circuiting during the assembly procedure. Quality is always top priority. During assembly the work lights are placed in specially made apparatus so that the production process can run more simply, more swiftly and also uniformly. The first step in the manufacturing process is the inserting of the circuit board into the housing. Dome-head pins, present in the housing, allow the circuit board to be centred in the work light. Then the reflector is put in place. In order to keep light loss in the system as low as possible, it is essential that the surface of the reflector is exceptionally smooth. This process takes place in the metallization system. Plastic components are covered with a metal powder coating in a vacuum chamber. And the result of this procedure is the forming of an especially smooth and indeed very clear reflective surface. The reward for this meticulous procedure is an even and homogeneous light distribution and illumination of the work area. The next step along the way is the gluing of the work light. It is vital to protect the electronics 100% against any

infiltration of water, dust or any other kind of contaminating influence (IP6K9K). So that a completely sealed system can be created, the gluing points are first meticulously cleaned to ensure that no contamination or leaks can occur. A robot then applies the glue in the designated adhesive bed. Finally the cover lens is put into position. The adhesive bonds with the aluminum housing and the lens, thus forming a sealed system. After the lens is firmly fixed in place, a function and tightness test is performed while the product is still on the assembly line. The HELLA premium products are all subjected to countless mechanical tests, electronic short-circuiting and EMC tests and also the toughest corrosion tests (withstanding up to 1,000 hours of salt spray testing), all of which they have to pass before being approved for series production. This is the only way to make certain that the customer really does get what he needs for his hard and demanding everyday tasks.

Out into the big wide world

The appropriate packaging is the final chapter in our work light story. And that depends on the type of customer on the receiving end. Although most of our work lights go out to Original Equipment customers in the agricultural and construction machinery sector, HELLA also makes this OE quality available for sale in the independent aftermarket. Individually packed in the classic HELLA design, the products are delivered to the main Logistics Centre located in Germany. This Logistics Centre serves as the main hub organising the distribution of products carrying the HELLA brand. More than 11,000 independent dealers and over 1,000 Original Equipment manufacturers are supplied from this depot. This centre enables HELLA to offer its customers, who can be found in more than 100 countries across the globe, excellent logistics and a high level of flexibility, day in day out. Which means that HELLA products can be on offer anywhere in the world within a very short space of time.



The reflectors are given their shiny surface coating in the vacuum chamber.

Close-Range Illumination

Article Number: 1GA 995 606-001 (Connection: 2-pin DEUTSCH)

Long-Range Illumination

Article Number: 1GA 995 606-011 (Connection: 2-pin DEUTSCH)



Decked out in the classic HELLA design and ready for dispatch to the sales partners.



Mounting A Light Bar On The Roof:
Dietmar Bengsch in action with the drill after using a template to measure requirements.

LED Light Bar 350 Work Light: Mounting

SLIM PROFILE, POWERFUL PERFORMANCE

Because of its compact, aerodynamic shape, the LED Light Bar 350 work light is undoubtedly one of the summer highlights to come out of HELLA. This 350 mm long elongated work light is an interesting alternative to the round, square or oval shaped ones. The light bar's 12 high-power LEDs generate light for the workplace which boasts 2,200 lumens and a colour temperature of 5,000° kelvin, very similar to daylight. Its total weight of just 660 gm coupled with an overall low height of only 60 mm makes this work light ideally suited for mounting on agricultural, forestry and construction machinery.

Easy Mounting

Dietmar Bengsch shows very convincingly how quickly the light bar can be mounted. The LED light bar is to be fixed on a JCB front loader. The front loader can be used in a variety of ways, either as a tractor or also for work with equipment requiring front and rear attachments.

prefers to use the universal brackets, which are delivered as an accessory. Mounting these is just as simple. The only difference from the standard bracket is that the light bar is secured at each end. This simply involves clamping the brackets into position at both ends of the light bar. When the bracket has snapped into place, you will hear a definite "click", signifying that the brackets are securely attached to the bar.

Now the light bar is ready to be secured to the cab roof's molding trim of the farming vehicle. The long screws are



An LED light bar/work light has been mounted with a universal bracket set: here the universal bracket can be seen already secured on the side.



Tightly screwed onto the roof molding trim. Particularly resistant to vibration.



Ideal for sloped mounting surfaces! The LED Light Bar is fixed into position with a lateral Allen screw.

LED Light Bar 350 Work Light

Product Range and Mounting Accessories:	Article Number
LED Light Bar 350	1GJ 958 040-501
Set of universal brackets	8HG 958 139-841
Accessories - universal brackets	8HG 958 139-071*
Switches	6EH 007 832-611
Deutsch plug	8JA 990 295-127

* Not used here (suitable for mounting with one's own sheet metal brackets or double mounting brackets 8HG 958 128-811)

Light Bar 350 Auxiliary Headlamp

with Plastic Bracket (ECE Ref.20)	1FJ 958 040-001
(ECE Ref.30)	1FJ 958 040-051
with Universal Bracket (ECE Ref.20)	1FJ 958 040-072
(ECE Ref.30)	1FJ 958 040-082

The mounting expert Dietmar Bengsch quickly found the perfect positioning for the light bar: directly on the cab roof's molding trim above the windshield. The light bar can be mounted there so that it does not extend beyond and overhang the actual vehicle dimensions. This advantage reduces the risk of damage caused by branches or by driving through narrow entrances. Dietmar Bengsch takes the measurements and, with the help of a drilling template, marks the drilling points needed for fixing the holding bracket. Using a 3-mm drill, he proceeds to pre-drill four holes into the cab to accommodate the two brackets and the cable feed-through. The 7-mm drill bit then comes into play to achieve the exact size required for the drill holes.

Mounting Brackets: Standard and Auxiliary

While the rust protection applied to seal the drill holes is still drying, Dietmar Bengsch affixes the light bar's two brackets. Delivered with the light bar are two standard brackets made of plastic. However, for mounting on the JCB, Dietmar Bengsch

inserted through each bracket and countered with a nut on the rear side of the molding trim's sheet metal. With the universal brackets, the support is mounted on the right and on the left of the light bar and fixed into position by means of a lateral Allen screw. When the bracket is secure and the angle of the light bar is in the required position, the screws can be tightened. The supply cable is fed through the pre-drilled cable duct into the cab and connected up to the lighting. This is possible either with its own switch or, alternatively, via a connection to the existing work lights.

It's a High Beam, too!

The Light Bar 350 is also available as an auxiliary headlamp for off-road use. Its external appearance is identical to the work light and it can be just as easily mounted with plastic brackets or universal ones. The range of the light given out by the ECE Ref. 20 model is just under 300 m and with the more powerful ECE Ref. 30 model it reaches over 350 m.

FINDING THE IDEAL WORK LIGHTS IS CHILD'S PLAY!

Anybody thinking about replacing the lights on his machinery can get advice in a specialist store, can pore over catalogues, ask colleagues ... What light is needed in the work situation? How far or how wide should this light extend? Now HELLA has come up with an alternative – the FREE WORKLIGHTS app, which is so simple and so instantaneous, it's child's play to operate!

The upcoming engineers Justus and Paul demonstrate here how easy it is. Using HELLA's WORKLIGHTS app, the two boys simulate which kind of light is most suitable. You just need a smartphone and a tablet (Apple iOS or Android) and then the app can be activated by visiting www.hella.com/apps. In the Product Finder, it is possible to select between seven types of vehicles showing suitable mounting positions. The app will then suggest the appropriate HELLA work lights for the given situation. Furthermore, detailed information, such as 3-D views, dimensions and illumination displays, is also shown. More than 30 HELLA work lights are showcased and on offer.

The selected and thus "virtually mounted" work light can now be observed from all angles. Paul and Justus put the various kinds of lighting and types of work lights through their paces. From the cockpit perspective of a traveling tractor, the LED, xenon and halogen types of lighting are all demonstrated in the front and rear of the vehicle and all from different angles.

The WORKLIGHTS APP has even more functions up its sleeve, such as "Brochure Live" showing all products in 3-D, user videos or a lighting dictionary packed with valuable information all about the subject of light. Even more fantastic support aiding selection of the ideal work light is offered by HELLA's online tool called ELIVER (www.hella.com/eliver), where it is possible to view the illumination performance of work lights very realistically as they are being used out in the field. You, too, can become a lighting expert!

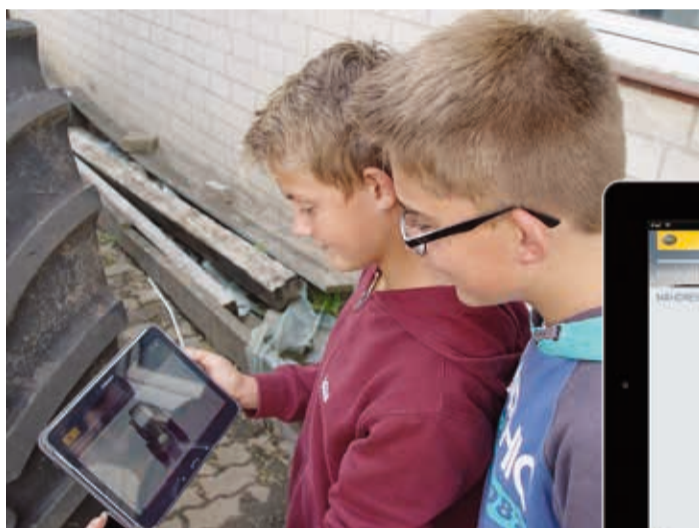

Paul and Justus test the work lights app on their father's tractor.



Various kinds of vehicle types can be selected.



Find the right light quickly without even touching a screwdriver. www.hella.com/eliver



Beacons

SAFETY THAT FLASHES OR ROTATES

The Rota LED beacon, boasting 20% more brightness than its predecessor's generation, is available in either the rotating version or the flashing one. The flat, compact design is dust-proof, waterproof and guarantees a long service life. Low-headroom entrances or overhanging branches often put an end to the working life of tall, towering rotating beacons. But not this one! Its reverse polarity protection facilitates connecting up. Low power requirements and high lighting efficiency speak for themselves. And thanks to its rubber base leading to high vibration resistance, the Rota LED stands out from the crowd. The shock-resistant dome made of polycarbonate protects against all manner of impacts and withstands many a knock with a branch. Three different mounting options offer solutions for every kind of use: permanent mounting as per DIN 14620 Form B1 (Ø 130 mm) and SAE (Ø 150 mm), magnetic attachment as per DIN 14620.



Flashing or 360° illumination:
The Rota LED in amber, red or blue.
Find out more information on HELLA beacons
by visiting www.hella.com/eliver

Rota LED Product Range		Article Number
Rota LED beacon, amber		
Rota LED F, permanent fixture	Rotating	2RL 010 979-001
	Flashing	2XD 012 878-001
Rota LED FL, for bracket	Rotating	2RL 010 979-011
	Flashing	2XD 012 878-011
ROTA LED M, with magnetic base	Rotating	2RL 010 979-021
	Flashing	2XD 012 878-021
Accessories, dome, amber		9EL 181 506-031
Rota LED beacon, blue		
Rota LED F, permanent fixture	Rotating	2RL 010 979-101
	Flashing	2XD 012 878-101
Rota LED FL, for bracket	Rotating	2RL 010 979-111
	Flashing	2XD 012 878-111
With magnetic base	Rotating	2RL 010 979-121
	Flashing	2XD 012 878-121
Accessories, dome, blue		9EL 181 506-011
Rota LED beacon, red		
No ECE approval – Use only as far as permitted by legislation. Not approved for road traffic in Germany, Austria and Switzerland.		
Rota LED F, permanent fixture	Rotating	2RL 010 979-201
	Flashing	2XD 012 878-201
Rota LED FL, for bracket	Rotating	2RL 010 979-211
	Flashing	2XD 012 878-211
ROTA LED M, with magnetic base	Rotating	2RL 010 979-221
	Flashing	2XD 012 878-221
Accessories, dome, rot		9EL 181 506-041

Switches

COMPATIBLE WITH CLAAS & FENDT



Clear Markings: Colour Symbols (for all manufacturers).

They are small, practical and they ensure safe operating even under demanding conditions. These switches can be easily replaced and they are no problem to operate even in tough working conditions – i.e. outside hazardous areas.

In line with IP Protection Class 64, the switches are optimally protected against dirt and water. Tailor-made for countless machines with function symbols such as:

- Raise/Lower Lifting Gear
- PTO (power takeoff shaft)
- Pull Out/Retract Attachment Parts

Article No.	Push button, waterproof			
6EF 004 406-101	Green Symbol: Pull out attachment part		6EF 004 406-141	Grey Symbol: Raise
6EF 004 406-111	Green Symbol: Raise lifting gear		6EF 004 406-151	Green Symbol: Cutting unit
6EF 004 406-121	Green Symbol: Lower lifting gear		6EF 004 406-161	Red Symbol: Power takeoff shaft
6EF 004 406-131	Green Symbol: Retract attachment part			

HELLA Wiper Blades

FITTING THESE BLADES - NO MONKEY BUSINESS HERE!

Smoothly functioning wiper blades are absolutely essential for clear visibility when it rains. It is very often the case that windshield wipers on agricultural and construction vehicles are only noticed when they stop working.

HELLA comes to the rescue with exactly the right range of wiper blades for such a situation. The rubber lip, which is nano-technically coated with graphite, guarantees even and quiet operating.

Replacing the garden variety of windshield wipers can quite often need some "high mathematical thought". But not if HELLA wiper blades are being used. In a short video our friend Fritz demonstrates how simple it is to change HELLA windshield wipers. Thanks to a pre-mounted adapter, fixing these into place is carried out in a matter of minutes. The high-quality, solid steel frame ensures maximum strength and durability and guarantees even contact pressure at each support point. Brand quality can be recognised by the original HELLA logo, which is embossed as a quality seal on every wiper blade.



Original HELLA wiper blades can be recognised by the embossed HELLA logo. (Similar to picture)

Wiper Blade	Lengths	Article Number
WA16 16"	400 mm	9XW 204 163-161
WA18 18"	450 mm	9XW 204 163-181
WA20 20"	500 mm	9XW 204 163-201
WA22 22"	550 mm	9XW 204 163-221
WA24 24"	600 mm	9XW 204 163-241



Fritz really is as agile as a monkey when fitting the HELLA windshield wipers. The fee for shooting this film was paid, incidentally, in bananas.



This way to the video.
www.hella.com/easychange



Thanks to its compact dimensions and high luminous efficiency, the Q90 compact LED is an all-rounder.

COMPLETE CORROSION PROTECTION THANKS TO THE INNOVATIONAL "THERMO PRO" PLASTIC HOUSING

Q90 COMPACT LED

The Q90 compact LED belongs to the family of the "Thermo Pro" work lights and, thanks to its compact dimensions, is a veritable all-round talent. The newly developed, heat-conducting housing is in no way inferior to the aluminum housing generally used and it provides particularly effective protection against salt and water. And with its light output of 1,000 lumens when consuming just 15 watts of energy, the Q90c is incredibly energy-efficient. In order to produce similar illumination, a comparable halogen work light needs the huge amount of 55 watts of energy. If money is to be saved long-term while at the same time reducing the load on the alternator of one's vehicle, it is certainly worthwhile replacing the old halogen lighting. Because of the higher colour temperature of 6,500° kelvin, LED light is very similar to daylight and therefore can create better and more comfortable working conditions, even at night.

This work light is totally resistant to pressure washing and is completely weather-proof.

Even under the most adverse environmental conditions which agricultural and construction vehicles have to face, the new Thermo Pro series has proved its worth. Another huge advantage is that also during the winter months these lights remain corrosion-free and consequently enhance safety in the working environment.

Close-Range Illumination

Article Number: 1GA 996 284-002 (Connection 200 mm cable)

Article Number: 1GA 996 284-081 (Connection 150 mm cable + Deutsch plug)

Long-Range Illumination

Article Number: 1GA 996 284-012 (Connection 200 mm cable)

Article Number: 1GA 996 284-091 (Connection 150 mm cable + Deutsch plug)

Operating

HELLA ACCELERATOR PEDAL WITH CIPOS TECHNOLOGY

Thanks to its contactless sensor technology, the HELLA accelerator pedal combines top-precision measuring with its robust and long-lasting design. The HELLA accelerator pedal is just as suitable for "upright" installation as for the "pendant" method. The very heart of the product is the well-established and reliable CIPOS technology, which HELLA has been successfully implementing in passenger cars for years. As the pedal is virtually wear-free, it

is predestined for use in agricultural, forestry and construction machinery, vehicles which frequently have to manoeuvre on the smallest of spaces when in use. The wear-free CIPOS technology is based on the principle of inductive and consequently contactless position measurement, which measures the pedal angle incredibly precisely and then transmits this information as an electrical signal to the engine control. However, the



HELLA is the global market leader when it comes to electronic accelerator pedals.

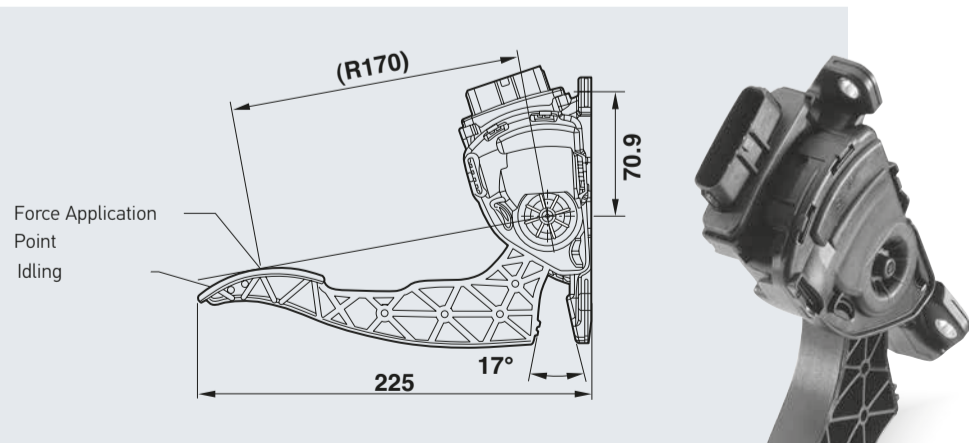

HELLA accelerator pedals are not sensitive to electro magnetic interference.

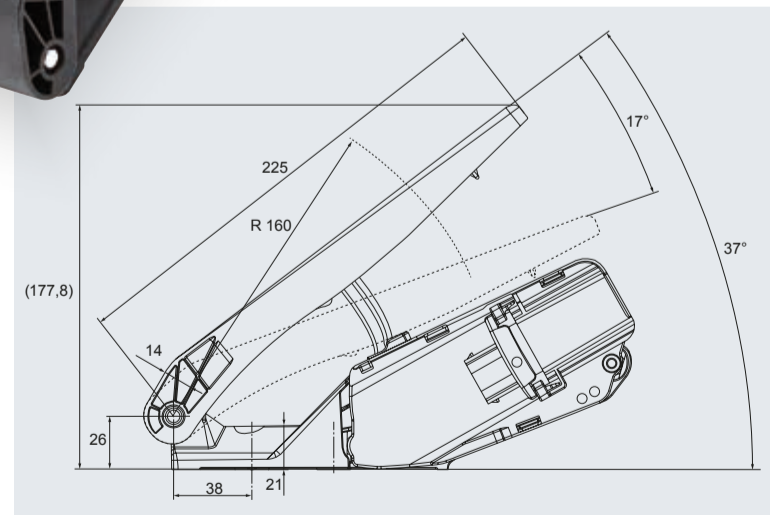

HELLA accelerator pedal is not sensitive to electrical and magnetic interference. And thanks to the housing made of fibreglass-reinforced plastic, the sensor is optimally protected against humidity and moisture. Looking back on more than 15 years of experience and turning over more than 20 million accelerator pedals per annum, HELLA is undoubtedly the world market leader in this field. This floor-mounted

accelerator pedal from HELLA is a standard product not restricted to use with any one particular customer and, therefore, is also available to order in small quantities.

Accelerator Pedal, upright
Article Number: 6PV 312 010-107
Accelerator Pedal, pendant
Article Number: 6PV 009 591-011

Mounting

TIPS FROM DIETMAR BENGSCHE, OUR PRACTICAL EXPERT

Not only the selecting of a suitable work light but also its correct mounting position on the equipment in question is crucial



With virtually every kind of job in the world of agriculture, the weather and its seasonal constraints are the factors which affect the land and make it passable or not, thus determining the working hours of farmers and contractors. And that is why, depending on the time of year, work is performed deep into the night. Anyone wishing to work safely and efficiently in the dark fully realises that high-performance work lights are an absolute must. However, a high lumen value alone is simply not enough to be able to work safely in the darkness of night. There are three other factors just as important as a powerful light: the positioning of the lights, their light distribution and also their alignment within the working area. Dietmar Bengsch, the HELLA mounting and assembly expert, has mounted countless work lights on the most diverse types of machines. This is his advice: "Before buying new lights, it is vital to first determine which area has to be illuminated. The next step is deciding where additional work lights can be positioned on the machine or which existing ones can be replaced," explains Dietmar Bengsch competently.

In general, illumination can be differentiated into two types:

1. Work lights for close-range illumination: These work lights can usually be recognised by their textured cover lens. The lens widens the light beams and distributes them homogeneously in the area of work. The result is an intensive lighting up of the vehicle or of the equipment being used and also large-scale illumination of the entire surrounding area.

2. Lights with long-range illumination: Here the reflector directs the light in the form of a narrower cone-like beam into the work area. Such variations are mostly used for lighting that is required in the distance.

But to cover every eventuality, Dietmar Bengsch recommends the following: "If you want to achieve a homogeneous, large-scale illumination of the work area, it is advisable to combine work lights that offer different kinds of illuminating features. In order to create an optimal result, it is not enough to simply fix the work lights onto the machine."

By selecting the right combination of close-range and long-range work lights and by adjusting them correctly, it's amazing how an extremely satisfactory result can be achieved. The work lights should be aligned so that the transitions between close and long-range illumination blend together, thus preventing any dark spots from appearing in the light field or in the field of vision.

And in the words of Dietmar Bengsch: "To do that, you have to master a few little tricks."

1. The selection of illumination: The first step is always to ask yourself how much light is actually needed (too much can result in glare) and where exactly this is needed. Then, after you purchase the new LED work light, the next step is for you to mount it.

2. The positioning of the work lights: The height at which the lights are mounted is the crucial factor in the illumination effect. Heights of more than 2.5 m are ideal. "When mounting lights, it's recommendable to tighten the bracket by hand so that it's still possible to train the work light on the area that is to be lit up."

3. The tilt angle: As soon as the work lights are mounted, you should then concentrate on the tilt angles of each light and also on their lateral adjustment, i.e. alignment.

4. The illumination surface: The aim is the creation of a harmonious, streak-free illumination of the work area. Align the work lights in such a way that the long-range

and close-range illumination effects work well together and that a smooth transition is formed between them. Once you have found the optimal illumination scenario, tighten the screws accordingly.

Anyone who would first of all like to visualise the individual illumination possibilities can view and test the light distribution of the work lights under realistic conditions by visiting www.hella.com/eliver.

HELLA has a treasure trove of work lights on offer in its product portfolio. If you are in doubt as to which work light is best suited for your purposes, take a look here at the recommendations of Dietmar Bengsch:

Work Light	Article Number	Range of Application
Q90c LED	1GA 996 284-002	Pleasant close-range illumination (halogen replacement)
Oval 90 LED	1GB 996 386-001	Extremely wide-angle illumination of close-range field
Ultra Beam LED Generation II	1GA 995 506-001	Particularly powerful, intensive close-range illumination
Module 70 LED Generation 4	1G0 996 476-011	Provides good visibility in the distance
Module 90 LED	1G0 996 263-011	Illumination outstrips xenon light performance



For homogeneous illumination, it is vital to tailor the positions of the work lights so that they are compatible and perfectly in tune with one another. The right constellation of close-range and long-range work lights leads to the creation of optimal working light.

HELLA ULTRA BEAM LED GENERATION II TAKES THE "PROFI" TEST

The agricultural magazine known as "profi" once again performed an LED work light test at the end of last year. On behalf of the "profi" magazine, the lighting technology department of the TÜV Rheinland (German Technical Inspection Association) put 10 LED work lights from a variety of wholesalers and manufacturers through their paces. HELLA, too, took part in this test and backed one of its best horses in the race, the Ultra Beam LED Generation II. The criteria used to test the candidates included luminous yield, light distribution and energy efficiency. Our manufacturer specifications tallied with the measured values; when it came to luminous yield we were in the Top 3 and the HELLA light distribution harvested just as much praise.

No less crucial in the test were the quality features of density and electromagnetic compatibility (EMC) that had to be exhibited by the work lights. These tests, too, were passed by the HELLA candidates with flying colours and the Ultra Beam LED Generation II even emerged as one of the test winners. Proving that it's a veritable all-rounder with excellent light output.



Close-Range Illumination Article Number: 1GA 995 606-001
Long-Range Illumination Article Number: 1GA 995 606-011

HELLA Limited

Unit 6 Appletree Industrial Estate
Chipping Warden
Banbury, Oxon
OX17 1LL
England, UK
Tel.: (01295) 662400
Fax: 0800 7832571
E-mail: hella.sales@hella.com
Website: www.hella.co.uk

© HELLA KGaA Hueck & Co., Lippstadt
J01161/06.16
Subject to technical and price modifications

HELLA ON THE WEB

Contact HELLA direct: via LinkedIn or YouTube – HELLA is active in a number of social networks.



LinkedIn
www.linkedin.com/company/hella



YouTube
www.youtube.com/hellagroup



Facebook
www.facebook.com/hella4workingpeople



Online
www.hella.com/agriculture